

PERFORMANCE TEST METHOD FOR  
INTENSIVE USE CHAIRS

1. Scope. This test method describes procedures for evaluating performance characteristics of intensive use chairs. Intensive use chairs are designed to be used 24 hours per day in a severe use environment.

2. Summary of Method. This test method is similar to the American National Standard, ANSI/BIFMA X5.1-1985, tests for general-purpose office chairs. Fixtures and equipment used in that test method may generally be used in these tests. This performance test method for intensive use chairs differs from the above mentioned test method in the following ways:

In most cases higher performance values are required to ensure chair survivability in a severe use environment.

In some tests cyclic stepped loads are applied. This type of loading provides fatigue loading while keeping the total number of required cycles low by steadily increasing the load on the chair or chair component.

3. Definitions.

3.1 Disabling damage - Damage to the chair or component which is sufficiently great to prevent the chair or component from performing its intended functions or would in any way cause personal injury to the occupant or bystanders.

4. Description of Tests.

4.1 Cyclic Back and Back Tilt Mechanism Fatigue Test. Applies only to chairs with spring type tension controls. The entire chair shall be attached to a test platform via the base to prevent the chair from sliding backwards or overturning. Loads may be applied either with a pushing load-head or a pulling harness. A front-to-back load shall be applied to the back of the chair at a point 16 inches above the seat or to the top of the back if the back is lower than 16 inches. The load is applied in a manner so the load is normal to the plane of the back at the back stop position. The tilt mechanism shall be adjusted so that the top of the back moves 4 inches  $\pm$  1 inch

rearward under the action of a 40 pound load. The test is carried out at a 50 pound load level at 20 cycles per minute and is continued until the back or tilt mechanism suffers disabling damage or meets the required acceptance level.

4.2 Cyclic Increasing Back Load Test. The entire chair shall be attached to a test platform via the base to prevent the chair from sliding or overturning. Loads may be applied either with a pushing load-head or a pulling harness. A front-to-back load shall be applied to the back of the chair at a point 16 inches above the seat or to the top of the back if the back is lower than 16 inches. The load is applied in a manner so the load is normal to the plane of the back at the back stop position. If the chair uses a spring type tension control, the control shall be adjusted to its loosest position. If the chair uses an air cylinder or other mechanism which locks the chair inclination in a fixed position, the control shall be adjusted to the far backward position. The test shall begin at the 75 pound load level with the load increased in increments of 25 pounds after 25,000 cycles have been completed at the preceding load level. Testing continues until some type of disabling damage occurs or the chair meets the required acceptance level.

4.3 Cyclic Pneumatic Back Tilt or Seat Inclination Adjustment Mechanism Test. The entire chair shall be attached to the test platform via the base to prevent the chair from shifting position during the test. If a chair has a pneumatic back tilt or pneumatic seat inclination adjustment mechanism, they shall each be tested. The test shall use a four part cycle as follows:

- A. Seat or back is loaded with 50 pounds normal to the plane of the seat or back. The load shall be applied to the seat and the back at the location which will most easily cause the seat or back to tilt when the tilt activator is operated.
- B. Load is removed.
- C. Load is reapplied and adjustment mechanism is activated while chair is under load.
- D. Load is removed and adjustment mechanism remains activated until seat or back mechanism returns to normal position whereupon the adjustment is unactivated.

The entire cycle is repeated at a rate of 5 cycles per minute. The test is continued until some part of the adjustment system malfunctions or the chair meets the required acceptance level.

4.4 Cyclic Vertical Load Test on One Arm. The entire chair shall be attached to a test platform via the base to prevent the chair from overturning. A vertical downward load shall be applied to the approximate center of one arm rest of a chair at a cyclic rate of 20 cycles per minute. The test is begun at a load level of 100 pounds and increased in increments of 50 pounds after 25,000 cycles have been completed at the preceding load level. Loads are increased every 25,000 cycles until the chair suffers disabling damage or meets the required acceptance level.

4.5 Cyclic Side Thrust Load Test on Arms. The entire chair shall be attached to a test platform via the seat to prevent it from sliding sideways, overturning or rotating in the direction of the load. The seat shall be restrained in a manner so that the arm is not supported. A cyclic outward side thrust load shall be applied to an arm of the chair at a rate of 20 cycles per minute. The load shall be applied to the approximate midpoint on the length of the arm normal to the vertical plane of the arm. The test shall be begun at the 50 pound load level. Loads are increased in increments of 25 pounds after 25,000 cycles have been completed at each preceding load level. Loads are increased every 25,000 cycles until the chair suffers disabling damage or meets the required acceptance level.

4.6 Cyclic Vertical Load Test on Seats, Bases and Casters. The entire chair shall be attached to a test platform via indentations that contain the casters and prevent them from rolling or rotating on the spindle. A vertical load shall be applied to the seat at a rate of 20 cycles per minute. Loads are applied 2 inches in front of the longitudinal axis of the spindle with a circular load-head 6 to 8 inches in diameter. The test is started at the 200 pound load level and loads are increased in increments of 100 pounds after each 25,000 cycles have been completed at the preceding load level. The casters shall be turned at right angles to the legs so that all legs are subjected to torsional forces. Testing continues until some type of disabling damage occurs or the chair meets the required acceptance level.

4.7 Cyclic Fatigue Test of Swivel Bearings. The chair minus the seat structure shall be secured to a platform that is rotated back and forth 360 degrees each cycle. The platform is cycled 10 times per minute. A static load of 200 pounds is placed on the chair so that its center of gravity is located 4 inches in front of the longitudinal axis of the spindle. The load is increased every 25,000 cycles by 25 pounds. The

rotating platform secured to the chair base is rotated beneath the seat side of the chair control while the seat side of the control is loaded vertically and secured to prevent it from rotating. The amount of torque required to cause the chair to rotate from a stopped position is measured every 25,000 cycles. The static load is also applied when the torque measurement is taken. The testing is continued until the torque rises above the acceptance level or the chair completes the required load level in the acceptance level.

4.8 Cyclic Pneumatic Height Adjustment Durability Test. The entire chair shall be attached to a test platform via the base to prevent the chair from shifting position during the test. The height adjustment mechanism shall be tested using a four part cycle as follows:

- A. Seat is loaded with 250 pounds.
- B. Load is removed.
- C. Load is reapplied and adjustment mechanism is activated.
- D. Load is removed and adjustment mechanism remains activated until seat ascends to highest position whereupon it is unactivated.

The entire cycle is repeated at a rate of 5 cycles per minute. The test is continued until some part of the adjustment system malfunctions or the chair meets the required acceptance level.

4.9 Front Stability Test. The front stability test shall be conducted as follows:

- A. Chair is placed on a level test platform at lowest height setting.
- B. The base and casters are placed in their most unstable position.
- C. A downward vertical load is applied to the front center edge of the seat. The load in pounds required to just lift the rear caster off the test platform is recorded as the measure of front stability.

4.10 Back Stability Test. The back stability test shall be conducted as follows:

- A. Chair is placed on a level test platform at lowest height setting.
- B. The base and casters are placed in their most unstable position.

- C. A 1 inch high obstruction is placed behind the two rearward casters.
- D. The front edge of the seat is loaded with 50 pounds applied in a similar manner as in the front stability test.
- E. A horizontal front-to-back load is applied to the top of the back rest. The force required to overturn the chair multiplied by the height from the floor to the top of the backrest is recorded as the measure of back stability.

4.11 Caster and Base Durability Test. A chair with casters mounted shall be placed on the obstacle layout as indicated in Figure 1. A 300 pound load shall be applied to the chair seat as indicated in Figure 1 with the chair spindle fully extended. The base shall be attached to a mechanical device which shall exert a horizontal push and pull of from 30 inches to 34 inches as illustrated in the figure. The base and casters shall be free to rotate and swivel. The machine shall operate continuously at a rate of 8 to 10 cycles per minute with a maximum speed of 50 feet per minute. One cycle shall consist of a forward and backward stroke of the mechanical device. Testing continues until the base or a caster suffers structural breakage, loss of serviceability, failure that would in any way cause personal injury to the occupant or bystanders, or meets the required acceptance level.

4.12 Fabric Durability Test. The fabric shall be tested in accordance with the surface abrasion test in ASTM D 3597 or ASTM D 3884 (using CS #10 wheels and a 500 gram load). If the ASTM D 3597 surface abrasion test method is used, the bidder must extend a 5 year (from receipt of chair) warranty on the fabric life. If the fabric wears through while in the anticipated intensive use environment during the warranty period, the contractor shall supply a complete re-upholstery kit as defined in the contract.

4.13 Spindle Attachment Tests. The control and spindle shall be detached from the chair and tested as follows:

- Test A) Apply a torque of 100 foot-pounds to turn or displace the spindle from the control by use of a tool such as a wrench.
- Test B) Apply a force of 1,500 pounds to the spindle in the direction of its removal from the control at the rate of 0.100 to 0.125 inch per minute.

When a free swiveling fitting is used to attach the spindle to the control, Test A may be disregarded.

5. Acceptance Levels.

<u>Test</u>	<u>Acceptance Level</u>
4.1 Cyclic Back and Back Tilt Mechanism Fatigue Test	1,000,000 cycles
4.2 Cyclic Increasing Back Load Test	Complete 175 lb. Load Level
4.3 Cyclic Pneumatic Back Tilt or Seat Inclination Adjustment Mechanism Test	(Not yet specified.)
4.4 Cyclic Vertical Load Test on One Arm	Complete 250 lb. Load Level
4.5 Cyclic Side Thrust Load Test on Arms	Complete 200 lb. Load Level
4.6 Cyclic Vertical Load Test on Seats, Bases and Casters	Complete 1,300 lb. Load Level
4.7 Cyclic Fatigue Test of Swivel Bearings	Max. 150 in. -lbs. at 300 lb. Load Level
4.8 Cyclic Pneumatic Height Adjustment Durability Test	125,000 cycles
4.9 Front Stability Test	Min. 125 lbs.
4.10 Back Stability Test	Min. 1,450 lb. - in.
4.11 Caster and Base Durability Test	36,000 cycles
4.12 Fabric Durability Test	ASTM D 3597 - 30,000 cycles without any noticeable wear. ASTM D 3884 - 15,000 cycles without wearing completely through any warp or fill yarn.
4.13 Spindle Attachment Tests	Spindle shall remain unmoved after completion of Test A and Test B.

6. Reporting Requirements. Upon completion of each test, the official report (Form A) must be completely filled out and documented with photographs as required.

7. References. The following documents of the issues in effect on date of invitation for bids or requests for proposal, form a part of this specification to the extent specified herein.

American National Standards Institute (ANSI) Standards:

ANSI/BIFMA X5.1-1985 - General-Purpose Office Chairs - Tests

(Application for copies should be addressed to the American National Standards Institute, 1430 Broadway, New York, NY 10018.)

American Society for Testing and Materials (ASTM) Standards:

ASTM D 3597 - Woven Upholstery Fabrics - Plain, Tufted or Flocked

ASTM D 3884 - Abrasion Resistance of Textile Fabrics (Rotary Platform, Double-Head Method)

(Application for copies should be addressed to the American Society for Testing and Materials, 1916 Race Street, Philadelphia, PA 19103.)

Preparing Activity:  
GSA/FSS/FCNE

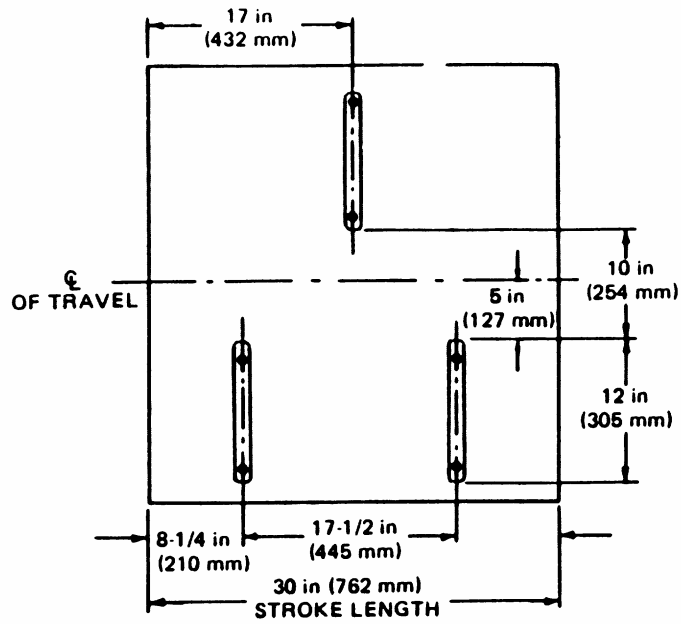

**OBSTACLE LAYOUT**

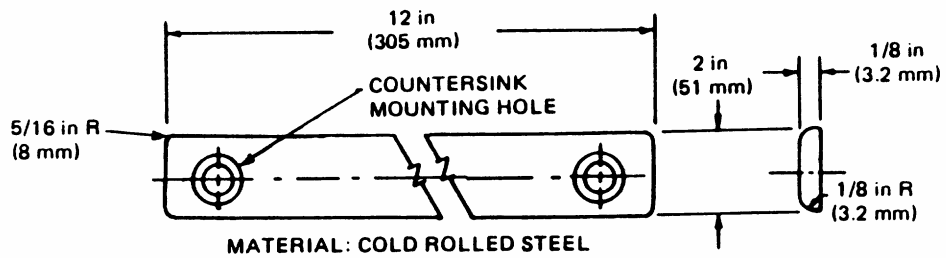

**OBSTACLE DETAIL**

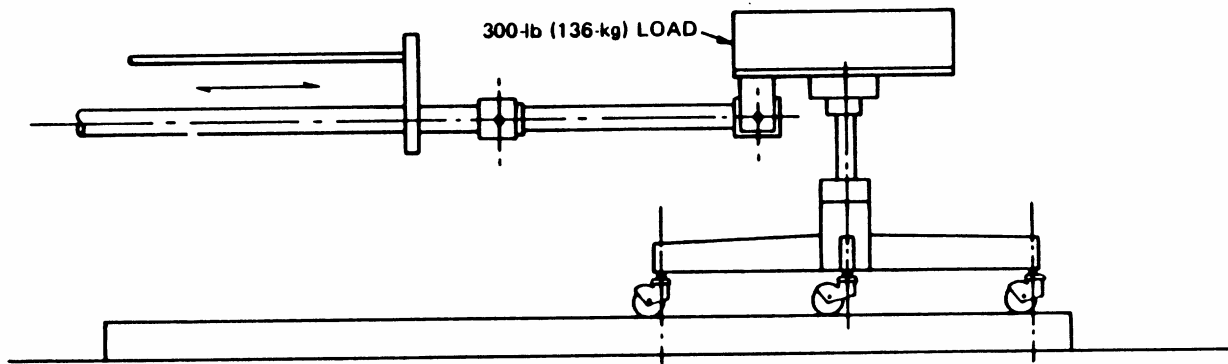

**TEST FIXTURE**

**Figure 1  
Caster/Chair Base Durability Test**

FORM A. Report of Furniture Performance Test.

Date:

Manufacturer:

Manufacturer's Model No.: \_\_\_\_\_

\_\_\_\_\_

\_\_\_\_\_

Name of test performed (submit original photograph of Test Set-up with specimen in place taken before testing began.) \_\_\_\_\_

\_\_\_\_\_

Last successful load level: \_\_\_\_\_

Other relevant information: \_\_\_\_\_

\_\_\_\_\_

\_\_\_\_\_

\_\_\_\_\_

\_\_\_\_\_

Testing Laboratory \_\_\_\_\_

Laboratory technician \_\_\_\_\_ Title \_\_\_\_\_

Signature \_\_\_\_\_

Certified by \_\_\_\_\_ Title \_\_\_\_\_

Signature \_\_\_\_\_